

T O W N H O M E

ESSENTIAL FEATURES



73 BRAUN AVE

NORTHCREST TOWNS, TILLSONBURG

THE DETAILS

PRICE	\$510,000
CLOSING DATE	Available Now
LOT NUMBER	103C, PHASE 2
BEDROOMS	3
BATHS	2.5
SQFT	1551
GARAGE	1
MODEL	2 STOREY TOWN

HAYHOE™
—HOMES—



SALES PROFESSIONAL

LAURA BABCOCK

519.520.0539

laura.babcock@hayhoehomes.com

SITE PLAN

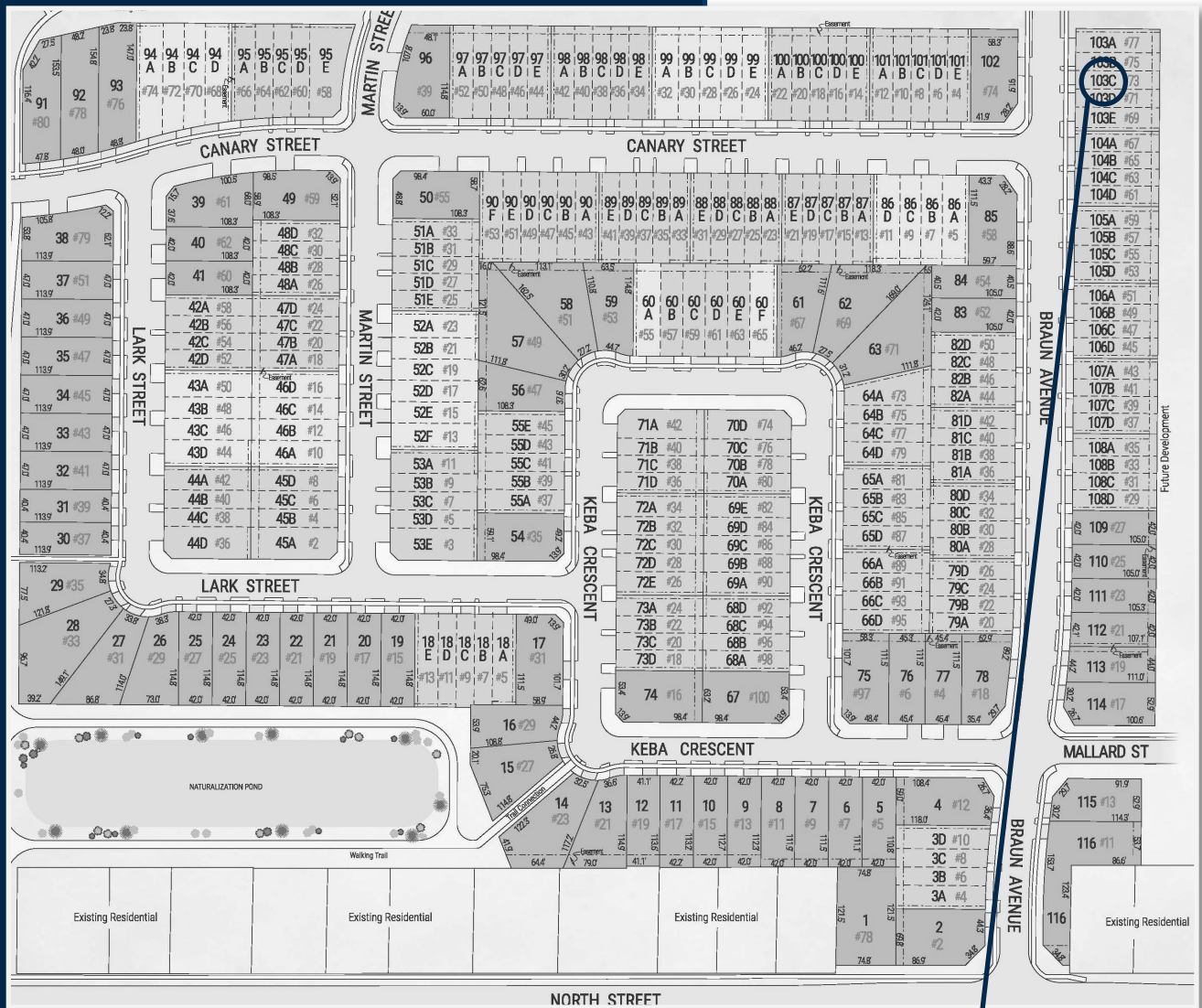

73 BRAUN AVE

EXTERIOR FEATURES:

- KEYLESS ENTRY
- TREATED WOOD DECK
- ASPHALT DRIVEWAY
- WALKING TRAILS

HAYHOETM
HOMES

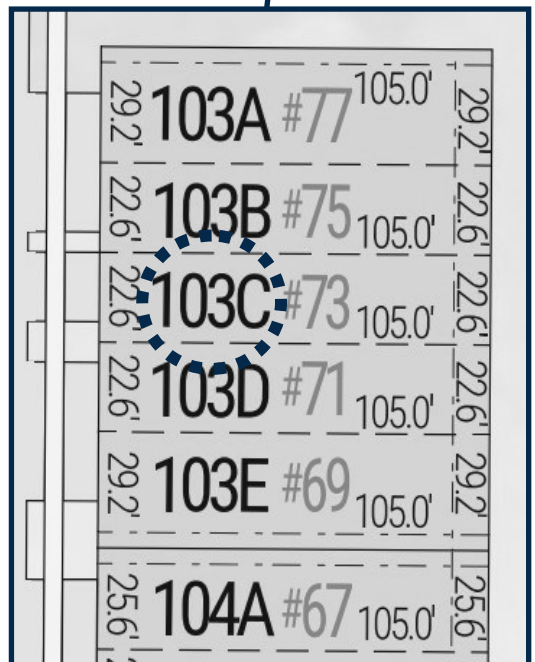

NORTHCREST
TOWNS

MAIN FLOOR

73 BRAUN AVE, TILLSONBURG

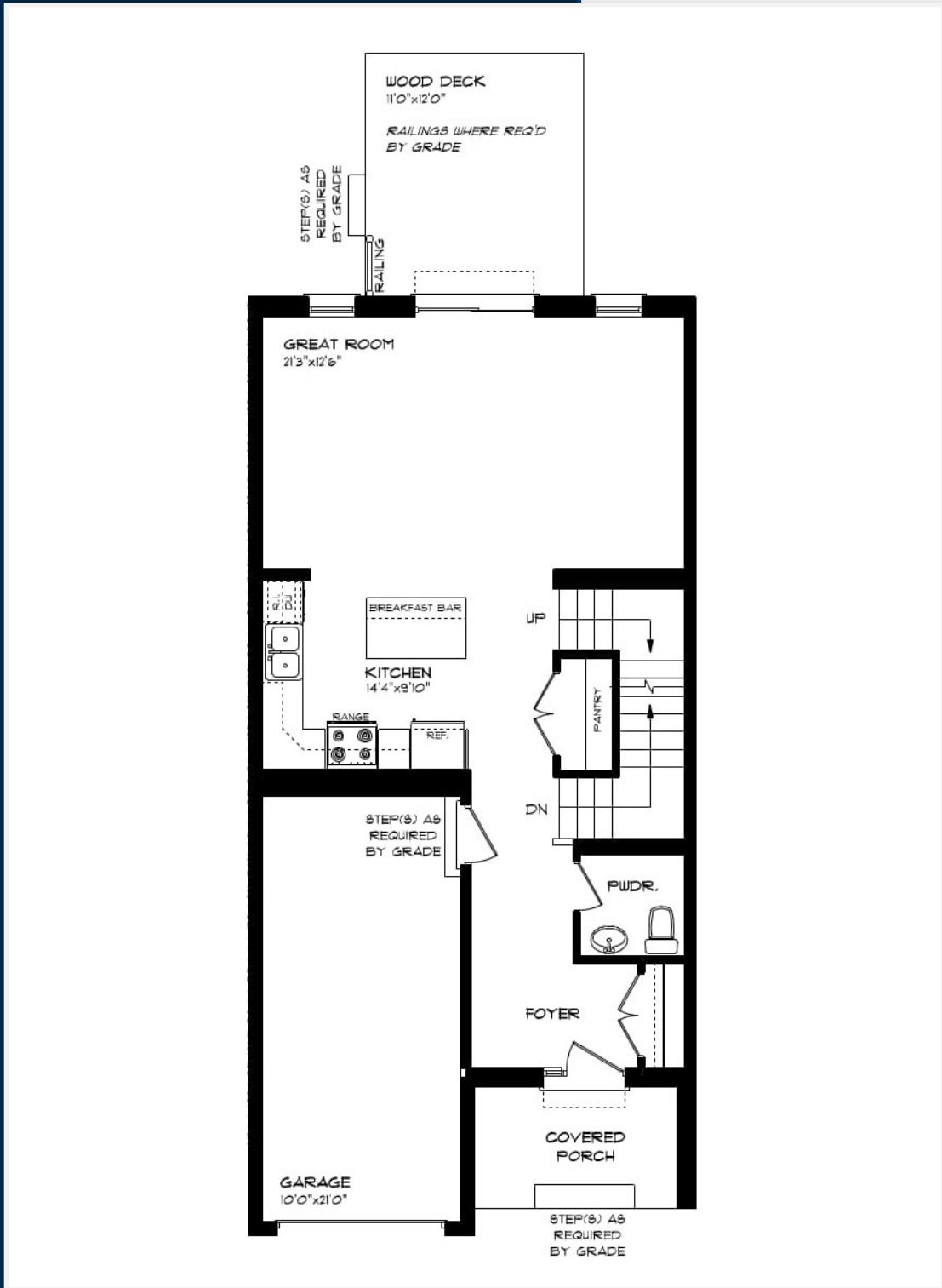

SINGLE CAR GARAGE

KITCHEN ISLAND

VINYL PLANK FLOORING

QUARTZ COUNTERTOPS

UNDERMOUNT SINK

MAIN FLOOR:
APPROX 725 SQFT

HAYHOE™
— HOMES —

SECOND FLOOR

73 BRAUN AVE, TILLSONBURG

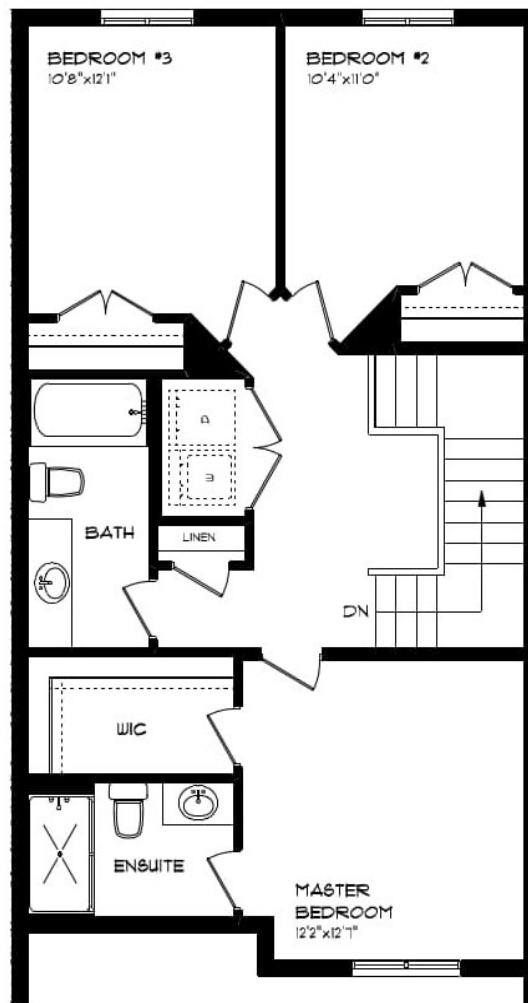

SECOND FLOOR:
APPROX 826 SQFT

SECOND FLOOR LAUNDRY
PROFESSIONALLY DESIGNED
CARPET FLOORING
VINYL PLANK FLOORING
WALK-IN CLOSET

HAYHOE™
—HOMES—

BASEMENT

73 BRAUN AVE, TILLSONBURG

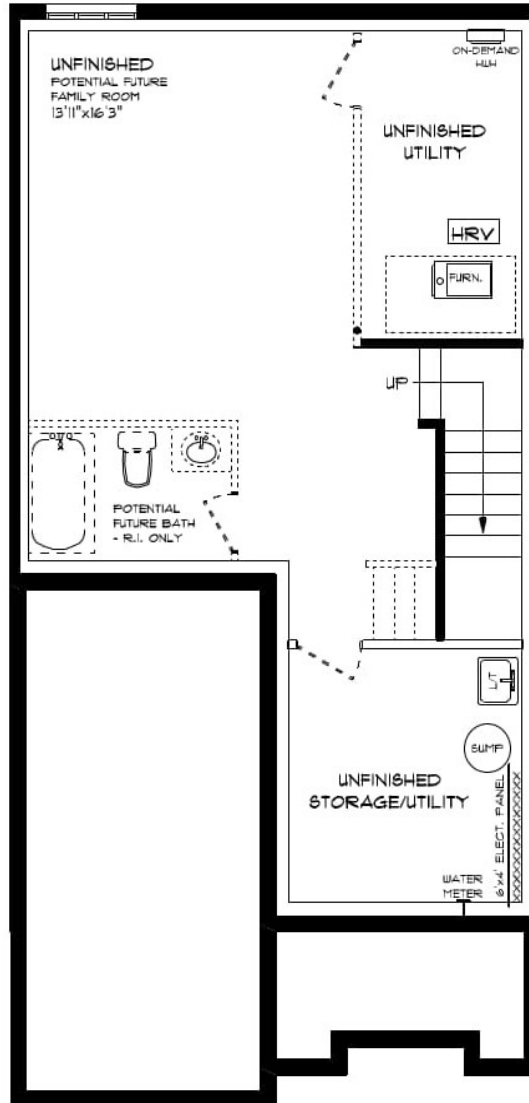

BASEMENT:
UNFINISHED

AIR CONDITIONING
GAS FURNACE WITH HRV
HUMIDIFIER
NEW HOME WARRANTY

HAYHOE™
— HOMES —

INTERIOR FINISHES

73 BRAUN AVE



LUXURY VINYL PLANK

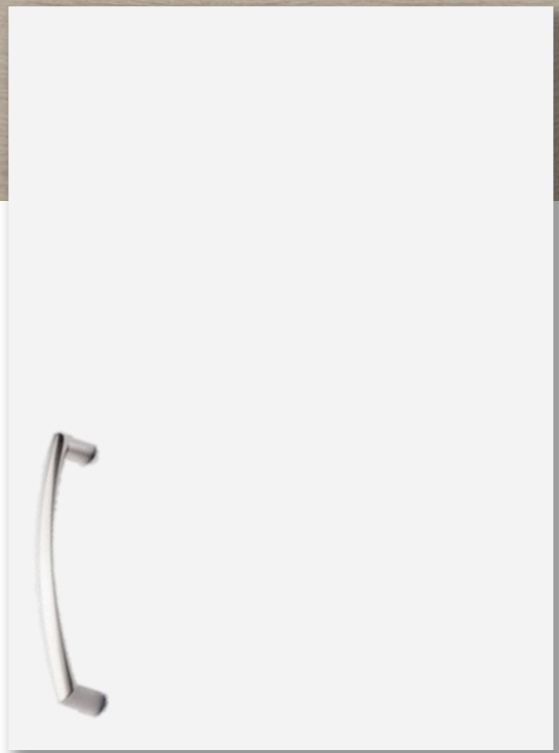

ISLAND
PENDANTS



KITCHEN
CABINETS

INTERIOR FINISHES

73 BRAUN AVE

INTERIOR DOOR STYLE



CARPET



BATHROOM
COUNTERTOP

BATHROOM
CABINERY

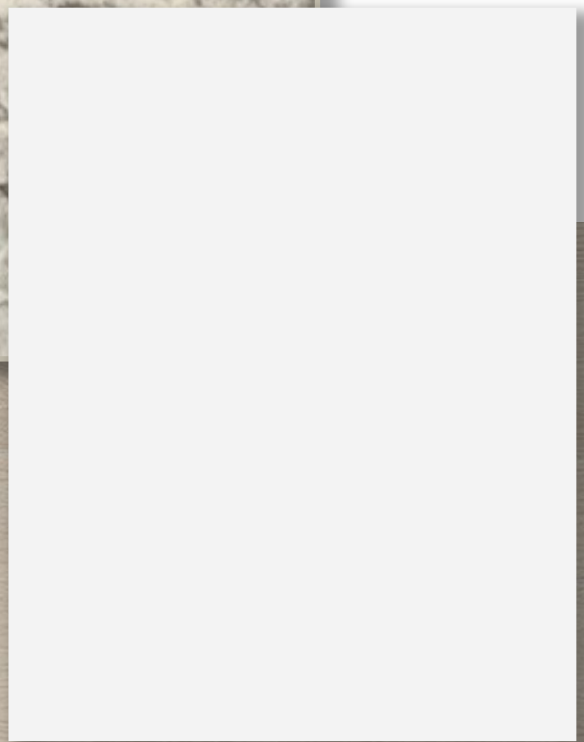
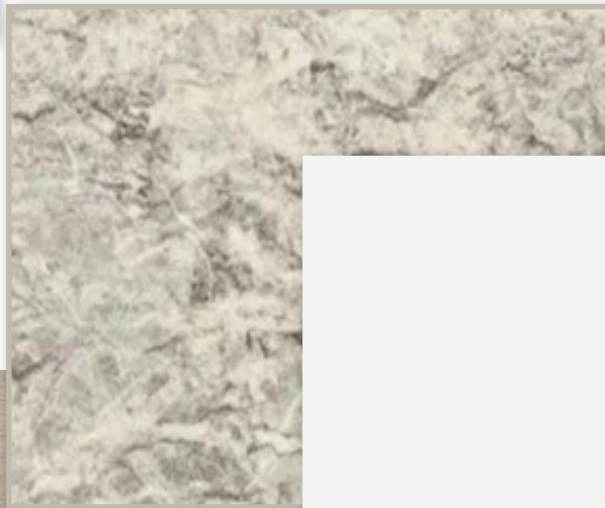

LUXURY VINYL PLANK

